

DIY599.com

RF linear power amplifier with build-in antenna tuner (ATU)

PA500

INSTRUCTION MANUAL

Version 2

operating frequency range between 3.5MHz-30MHz

The device requires an amateur radio transceiver to operate.

This device is for use by licensed radio amateurs only

FCC-ID: 2A2IEPA500

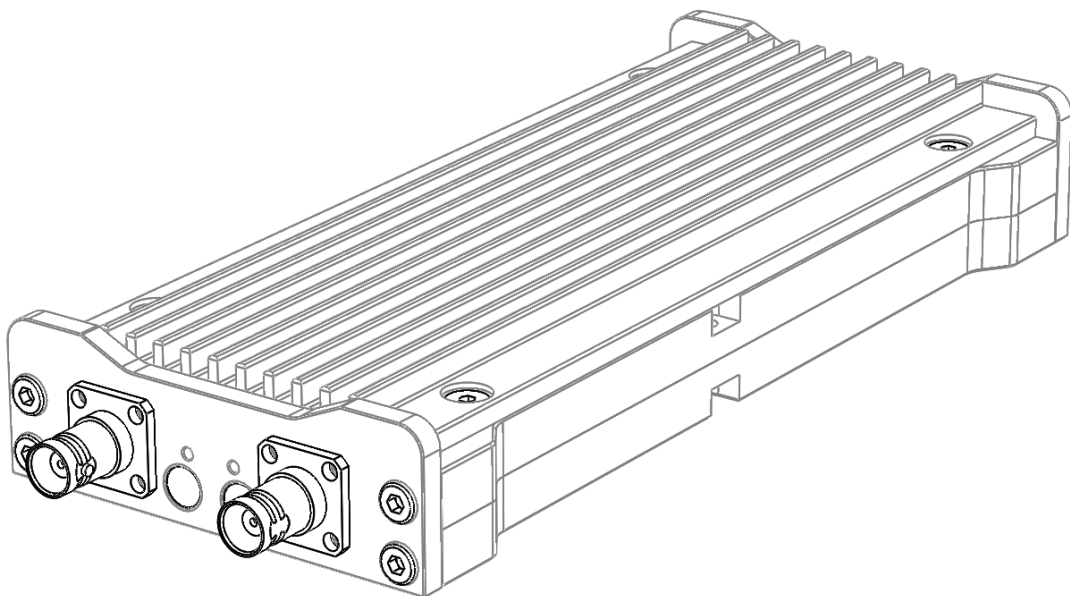

© 2021 DL4KA

connectors	3
getting started	4
powering up	4
LEDs and Button functions	5
device configuration	6
good to know about BYPASS Mode	6
good to know about automatic Mode	6
manual band selection	7
compatible transceivers	7
operating modes and drive power	8
Protective internal circuits	8
safety operating area SOA	9
special transceiver characteristics (in manual modes)	10
Connection cable wiring (for manual modes)	10
safety instructions	12
power considerations on the go	13
device specifications	13
GENERAL TROUBLESHOOTING	14
AFTER-SALES SERVICE POLICY	14
Device LABEL and ID location	15
WARRANTY LIMITATIONS	15
Note Amateur Radio Operation	16
WARRANTY TERMS	16
DISCLAIMER of LIABILITY	16

connectors

left side

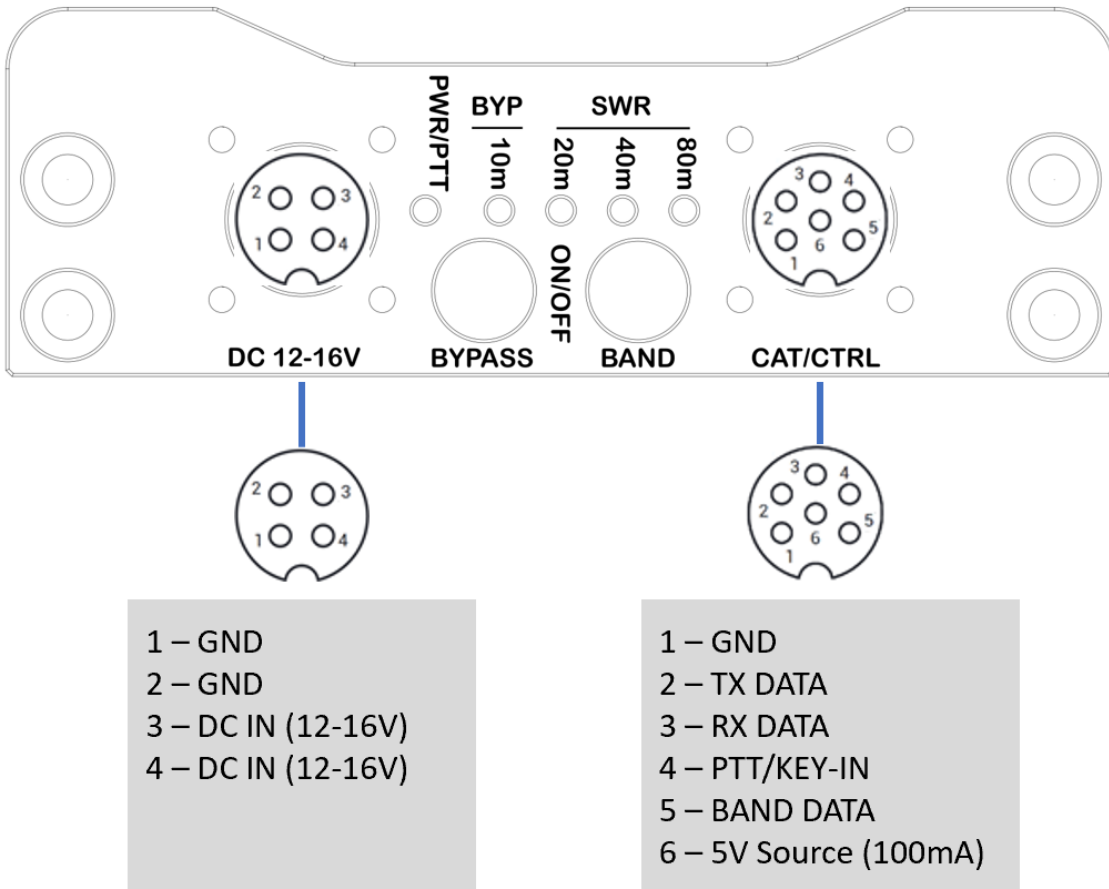

right side

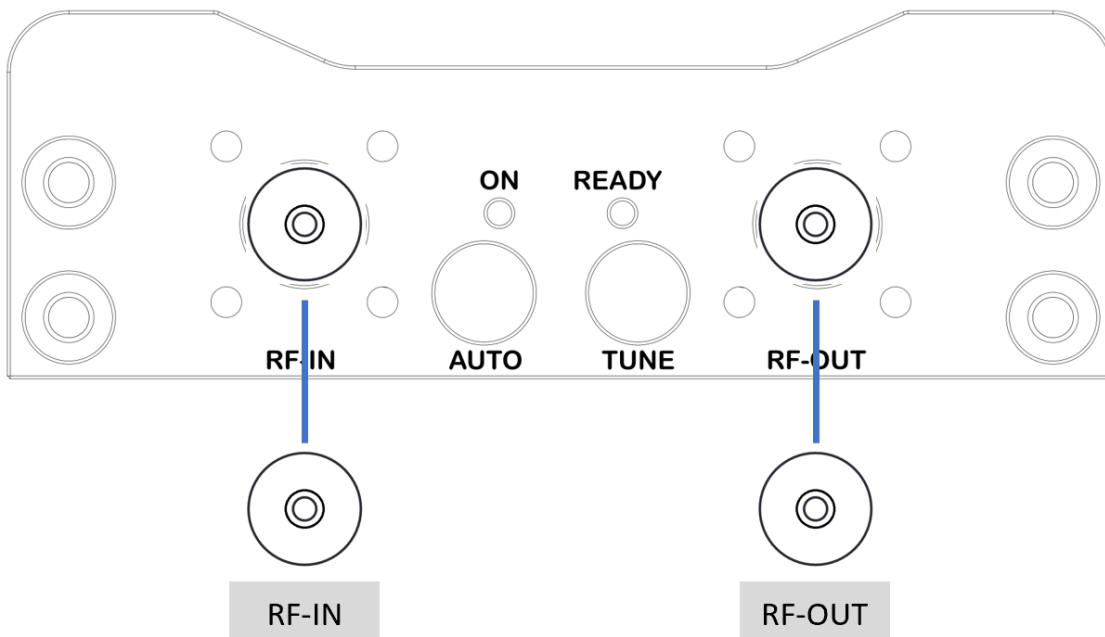

getting started

Before using the PA500, you'll need to connect a power source with a sufficient power. We recommend to use a power source (a battery or an AC/DC power supply) which can provide 12 to 16V and up to 10A of continuous current.



there is no reverse polarity protection, incorrect wiring will destroy the device.

The PA500 need to be connected to a transceiver. In the simplest case, a connection of the PTT signal from the transceiver is sufficient to control the PA. In this specific case, the frequency band to be used need to be set manually in PA-Mode (no bypass) on the PA500 (TAP the BAND Button).

Some transceivers provide an "analog band signal" to configure external devices like a PA. Another possibility is to obtain information from the transceiver via a digital interface (CAT). All of these three interface options are generally supported by the PA500. A list of the supported transceivers which provide a form of automatic frequency band reference will be find in the chapter "compatible transceivers".

powering up

After reading these brief instructions, you will be able to put the PA500 into operation.

1. Make sure that the transceiver with its RF-Out is connected to the RF-In connector of the PA500 using a suitable 50 Ohm antenna coax cable. A suitable antenna must be connected to the RF-Out connector of the PA500.
2. ~~Connect your transceiver and the PA500 with the appropriate control cable. This control cable is necessary, so that the PA500 can be switched accordingly by the transceiver during a transmission. If no special transceiver selection is made, the PA500 is in manual mode as well as in the bypass mode. A correct baud rate must be configured in the transceiver if the automatic band selection via the CAT interface is used.~~ **The new version of the PA500 supports RF-VOX-PTT, so no control cable needed between transceiver and amplifier.**
3. Please make sure that the Transceiver RF-Output-power is set to the correct level. See also section: 'operating mode and drive power'.
4. Switch on your transceiver and the PA500. To Power on the PA500, **TAP and HOLD the 'BAND' and 'BYPASS' button simultaneously for about 2 seconds**. After powering on, the white LED will light up. You can turn off the PA500 in the same way.
5. As mention before, **the PA is always in the BYPASS mode after powering on**. Tap the BYPASS Button once, the internal PA will be activated. You can switch back to 'BYPASS' in the same way.
6. ~~If you are in the PA mode (no bypass), select your Band to operate on the PA500 by tapping the 'Band' button.~~ **The new version of the PA supports automatic Band selection.** You can configure the PA into manual mode to set the band to operate manually.
7. Choose the antenna-tuner tuning-mode. You have the choice between "full-automatic" and "semi-automatic". Start with 'full-automatic', tap the 'AUTO' Button, the green light indicates the 'full-automatic' mode is switches on. The Antenna-Tuner will only work in PA-Mode.
8. Before you start to operate, tune your antenna, this should be done with an active PA (no BYPASS). It is recommended to switch to AM to tune the antenna with a steady carrier signal.

LEDs and Button functions

left side

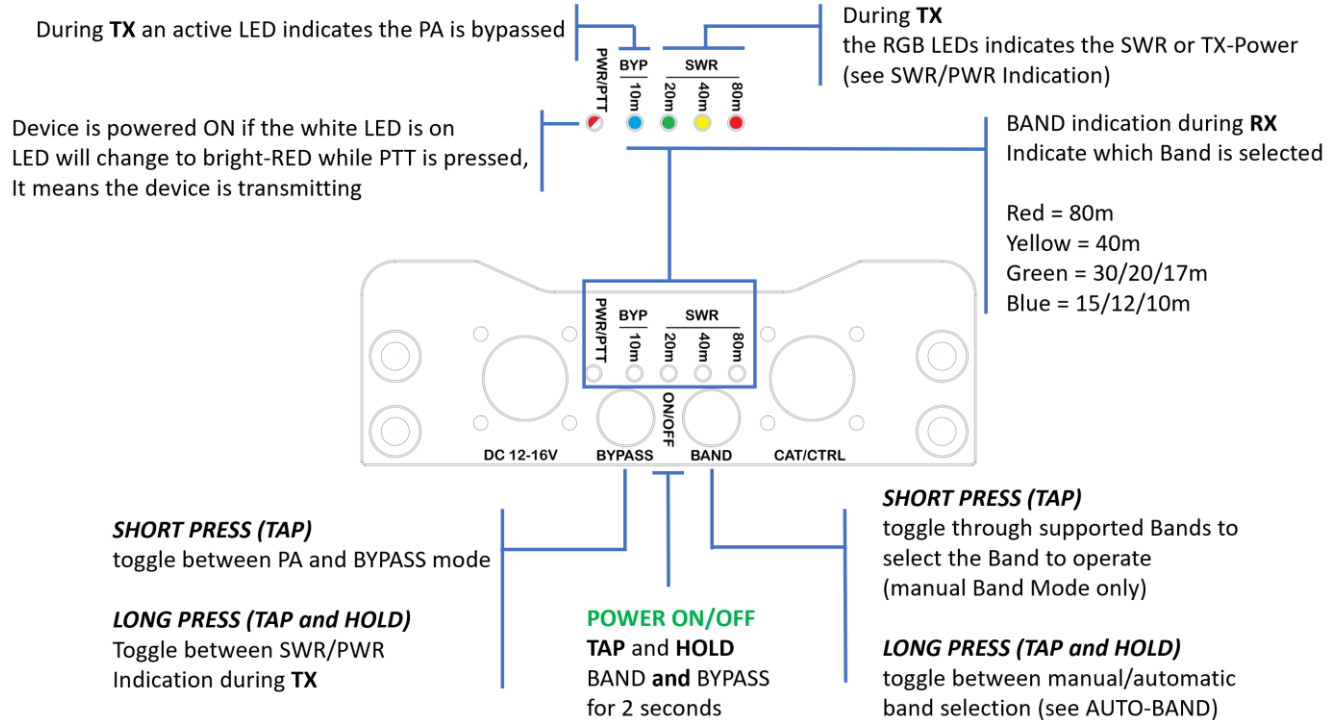

The correct Band must be selected, otherwise the PA will not transmit

right side

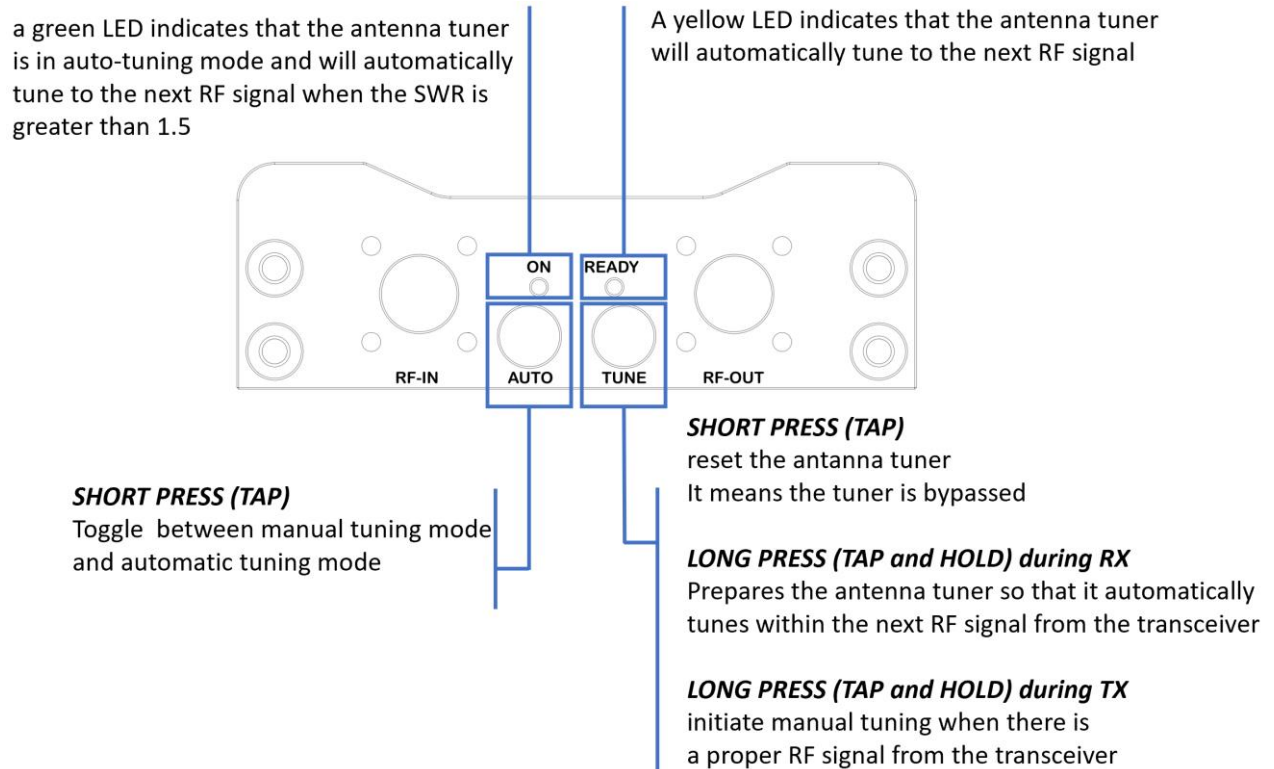

device configuration

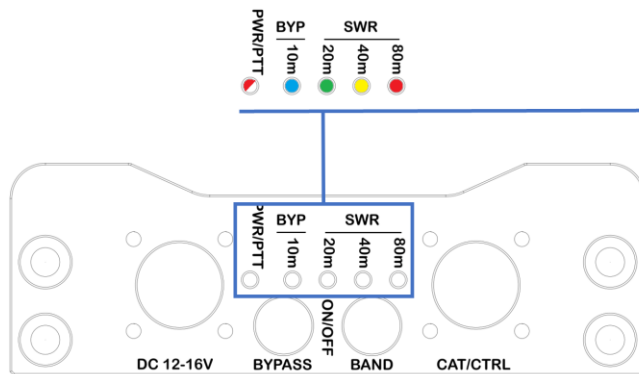

the binary code indicates which mode or transceiver is configured. Mode 0 (all LEDs off) is preconfigured

'see chapter: compatible transceivers'

BAND & BYPASS BUTTON
the two buttons have a secondary function to configure the PA to a specific transceiver to be used.

procedure to link the PA to your radio

1. PA must be powered OFF
2. **TAP** and **HOLD** the BAND and BYPASS Button for about 0.5 second
3. **CONTINUE TO HOLD** the BYPASS Button, release the BAND Button
4. PA will powered ON, indicated by the White LED
5. toggle through the modes with the **BYPASS** Button
6. **TAP** the **BAND** Button to save your setting to the device
7. **TAP** and **HOLD** BYPASS and BAND Button to turn OFF the PA

'see chapter: compatible transceivers'

good to know about BYPASS Mode

- if the PA is operated in the interface Mode 0 (simple PTT controlled) AND the PA is in the **BYPASS Mode**, Band-Filters are off, no LED indication for Filter status.
- if the PA is operated in the interface Mode 1-7 AND the PA is in the **BYPASS Mode**, Band-Filter LED shows the status of the selected Filter-Bank, but Band-Filters will switch off when the PTT is pressed.
- If the PA is in the **BYPASS Mode**, the Antenna Tuner is bypassed too.

good to know about automatic Mode

In case if you operate in the Mode 1,2,7 (see compatible Transceivers/configuration pattern). If you press the PTT button and you have selected a carrier modulation type, the PA will immediately make the appropriate filter setting. In the case of the carrierless modulation type SSB, the appropriate filter setting is only set after the corresponding modulation. This means that the filters are not set by pressing the PTT button, but only as soon as a modulation takes place that generates enough power for the internal VOX logic to configure the internal filters.

manual band selection

The PA500 has 4 Band selector settings 80m, 40m, 20m and 10m. Most of other Frequencies between these Bands can also be used. The table describes the selection that must be made for a specific Band to use.

operating Band	Band selector setting on the PA500	Band selector LED Color
80m	80m	RED
40m	40m	YELLOW
20m	20m	GREEN
17m	10m	GREEN
15m	10m	GREEN
12m	10m	BLUE
10m	10m	BLUE



Only HAM frequencies are supported, Frequencies between 26-28MHz are not amplified

SWR/PWR indication

During transmit the RED, YELLOW and the green LED will show the SWR which is achieved by the Tuner. This setting is pre-selected. Alternatively, the RF output power can also be displayed.

To toggle between both operation modes, **TAP** and **HOLD** the BYPASS Button.

SWR indication:	RF Power indication:
RED LED indicates a SWR > 2.5 YELLOW LED indicates a SWR 1.5 - 2.5 GREEN LED indicates a SWR < 1.5	NO LIGHT indicates RF Power < 10W GREEN LED indicates RF Power >= 10W YELLOW LED indicates RF Power >= 25W RED LED indicates RF Power > 40W

compatible transceivers

Transceiver model	Interface type	Interface#	PA configuration pattern **
all devices All transceivers with PTT out Signal	Manual mode	0	
all devices automatic Band selection	automatic Mode PCB Version 2.7 and above	1	
all devices* automatic Band selection automatic RF-VOX PTT	automatic Mode* PCB Version 2.7 and above	2*	
all devices automatic Band selection	automatic Mode* PCB Version 2.4 -V2.6	7	

* Default setting

operating modes and drive power

operating mode	max. drive power PEP	peak drive power PEP	max. PEP RF power*	transmit duty cycle @ max. RF power
SSB	3W***	5W	40W*****	periodic SSB
CW	3W@12V/2W@16V	-	30W**	max. 3min. continues carrier*** duty cycle 50/50 for 6min. ***
AM	3W@12V/2W@16V	-	30W**	max. 3min. continues carrier*** duty cycle 50/50 for 6min. ***
FM	3W@12V/2W@16V	-	30W**	max. 3min. continues carrier*** duty cycle 50/50 for 6min. ***
DIG	3W@12V/2W@16V	-	30W**	max. 3min. continues carrier*** duty cycle 50/50 for 6min. ***

* RF output Power can be reduced by the protection system depends on the case temperature

** the rated output power is limited due to the heat development

*** continues transmit time is limited due to the heat development

**** the maximum allowed output power is typically reached at an input power of 2W PEP ,

***** high operating voltage and peak input drive power, this setting may violate other operating conditions. if the nominal RF-Power exceeded by 1dBm, the PA will switch into the bypass mode.



Overdriving the PA leads to the harmonic distortion exceeding the permitted limits. The PA switches to bypass mode when the maximum output power is exceeded by 1 dBm.



The maximum output power is achieved with a matched antenna. If the antenna is not matched, tune the antenna to the right impedance with the integrated antenna tuner.

Protective internal circuits

protective circuits	function
Input power limiter	Protect the RF LDMOS FET amplifier
Temperature monitoring	Regulate output power by temperature
Output power monitoring	Overpower protection switch
Overcurrent fuse	Overcurrent shut off

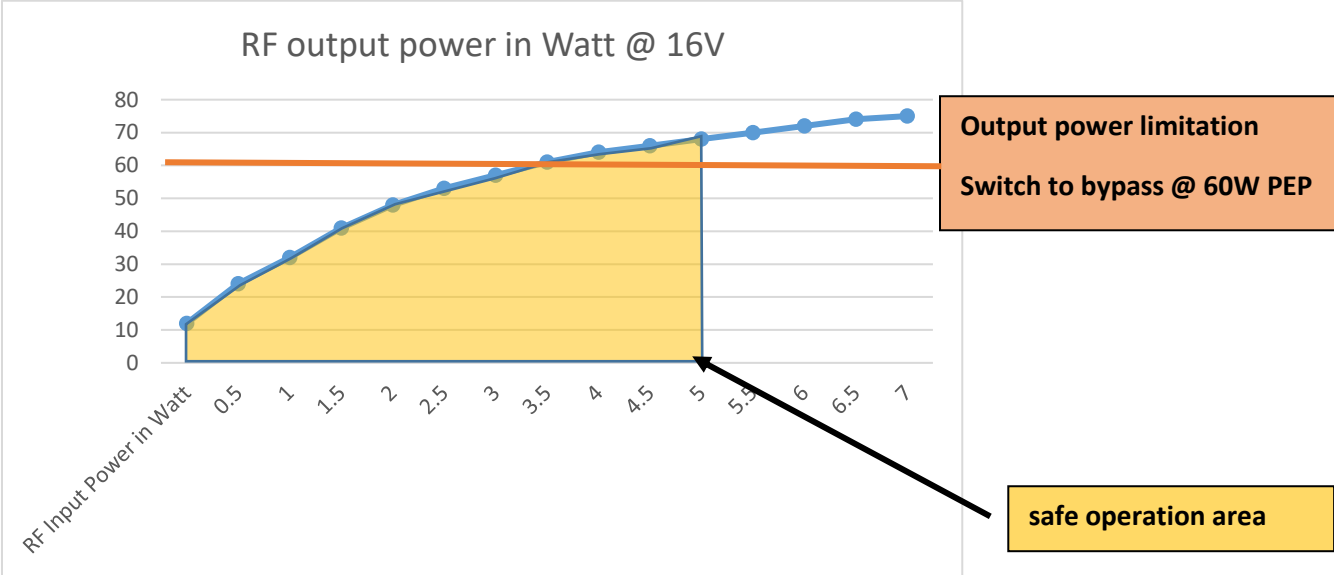

safety operating area SOA

RF output power vs. RF input power

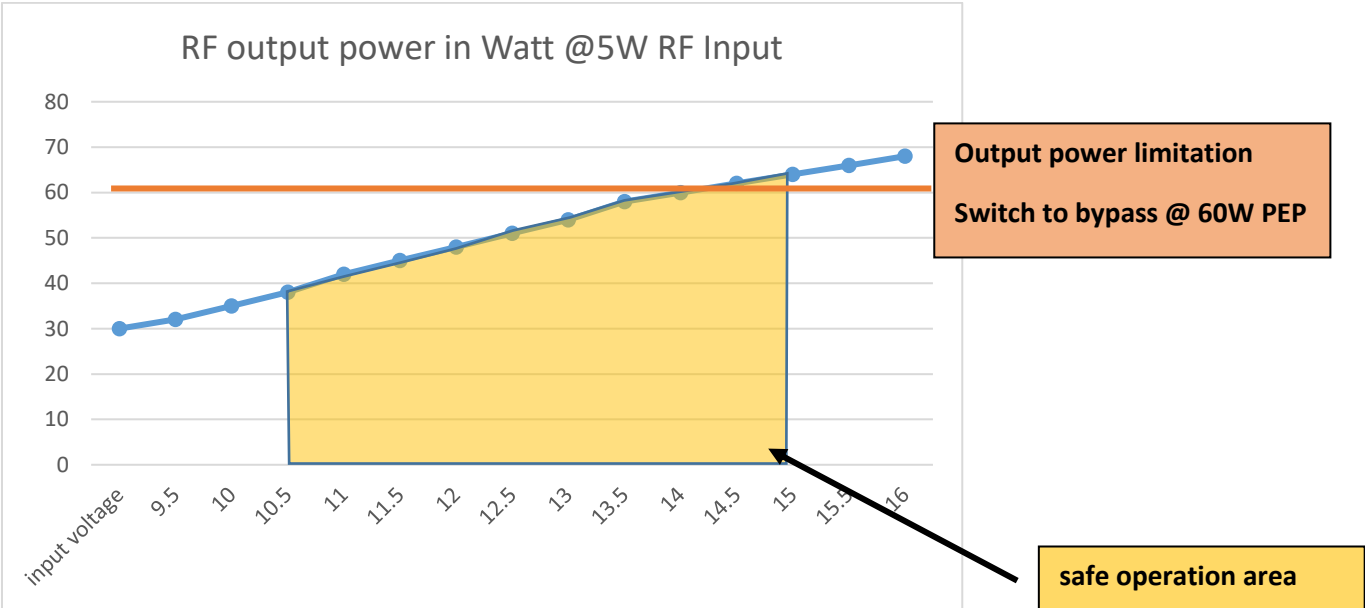

RF output power vs. operating voltage input



-  **Overdriving the PA leads to the harmonic distortion exceeding the permitted limits.**
-  **The maximum output power is achieved with a matched antenna. If the antenna is not matched, tune the antenna to the right impedance with the integrated antenna tuner.**
-  **This safety operation area may violate other operating conditions e.g., transmit duty cycle limits. Please see 'operating modes and drive power'.**

special transceiver characteristics (in manual modes)

some transceivers have specific characteristics associated with the operation of peripheral devices. Known characteristics in connection with the operation of the PA500 are listed here.

Yaesu FT817/818

If the Yaesu FT817/818 is used with a CAT interface cable, the transceiver will not turn on if the PA500 has already been turned on. Therefore, make sure that the transceiver is always switched on first and then the PA500.

ICOM IC-705

the IC-705 transceiver has several similar jacks. The SEND/ALC Jacks must be used for the connection with the PA500.

Connection cable wiring (for manual modes)

ICOM IC-705

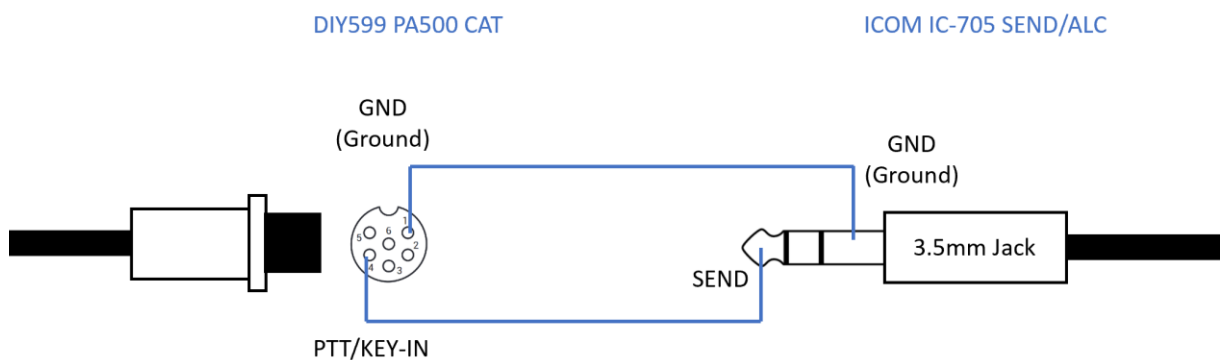

ELECRAFT KX2

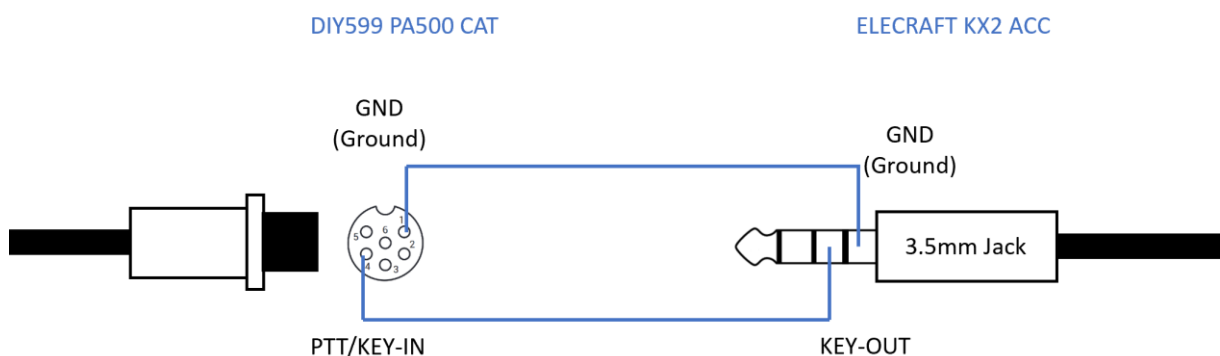

ELECRAFT KX3

DIY599 PA500 CAT

ELECRAFT KX3 ACC2

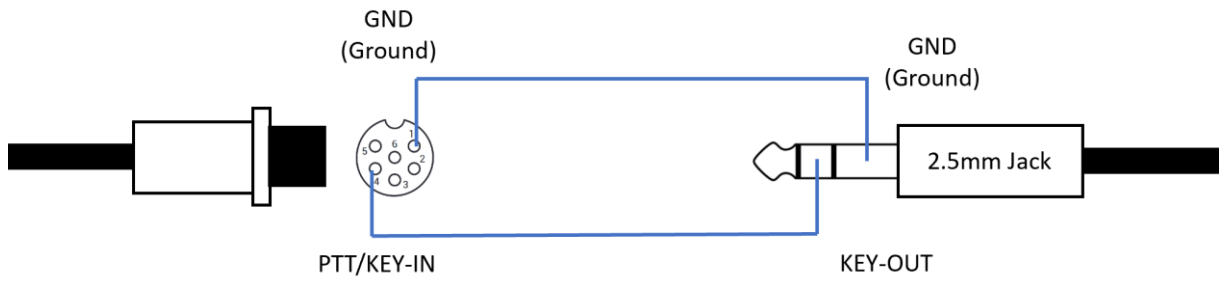

LAB599 TX-500

DIY599 PA500 CAT

Lab599 TX-500

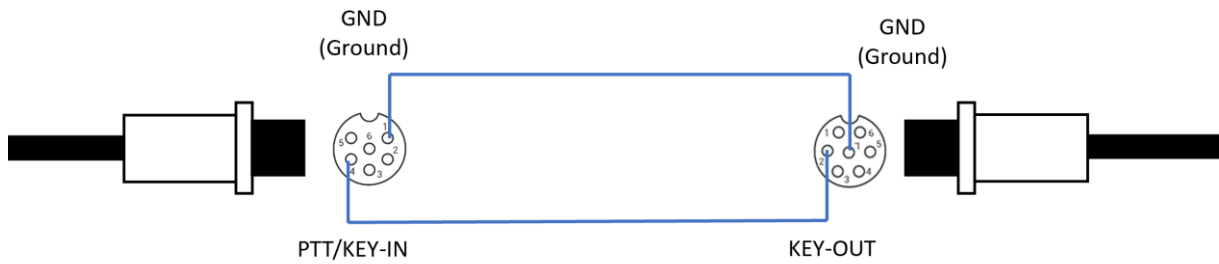

safety instructions

The device can get very hot. It must be operated in such a way that there are no heat-sensitive objects near the device. **Please ensure that the device is always well-ventilated during operation.** Please be aware that the device is still hot for a while after use. Please keep the device away from children, the device develops a temperature level which can cause burns to the skin.

temperature and ventilation

The device must be operated in such a way that ventilation is guaranteed at all times. Please never expose the device to direct sunlight. External ventilation may be necessary in extreme operating conditions.

EM interference

This equipment has been tested and found to comply with the defined limits for amateur radio equipment. This device is tested in a laboratory, all measurements were applied with suitable measuring devices. The device itself does not emit radio frequency energy to the antenna without a connected amateur radio transceiver. These limits are designed to provide reasonable protection against harmful interference in a residential installation. This equipment generates, uses and can radiate radio frequency energy when it's connected to an amateur radio transceiver and, if not installed and used in accordance with the instructions, may cause harmful interference to radio communications. However, there is no guarantee that interference will not occur in a particular installation. If this equipment does cause harmful interference to radio or television reception, which can be determined by turning the equipment off and on, the user is encouraged to try to correct the interference by one or more of the following measures:

- Reorient or relocate the receiving antenna.
- Increase the separation between the equipment and effected receiver device.
- reduce the output power until the device no longer interferes.
- Consult the dealer or an experienced radio/TV technician for help.

Operation is subject to the following two conditions: (1) this device may not cause harmful interference, and (2) this device must accept any interference received, including interference that may cause undesired operation.

CAUTION: Changes or modifications to this device, not expressly approved by DIY599 could void your authority to operate this device under compliance regulations.



This device is for use by licensed radio amateurs only

grounding and ESD protection

A connected transceiver should be connected to ground to provide some protection against lightning and damage due to electrostatic discharge (ESD). When used in a building, the connected transceiver should also be connected to other building grounds.

power considerations on the go

The "Buddipole POWERmini USB" is a pocket-sized 12 VDC portable DC power management system with built in solar controller that is particularly suitable for portable operations. This device can deliver up to 32A at 12V. this makes it a suitable device for supplying your transceiver and the PA500 with power on the go.

device specifications

	PA500
Amateur Radio Bands	3.5 - 29.7 MHz (max. SWR 3:1)
max. PEP RF output power (FM/AM(SSB/CW)	40W ^{***}
RF power gain	10dB-15dB
RF amplifier operation class	AB
Input impedance	50 Ohm
max. input drive level	5W [*]
Transceiver tune-up power (PA active)	1W-5W
Band coverage / frequency ranges	80m,40m,20m,17m,15m,12m,10m
Operating modes	SSB, AM, FM, CW, DIG
Harmonic distortion suppression below carrier	>43dB ^{**}
operating voltage	11-16V
max. power consumption (TX)	typ. 13.8V@8A
Power consumption (stand by)	typ. 13.8V@0.05A
Power consumption (sleep/off)	typ. 13.8V@0.01A
Control Interfaces	PTT/CAT/band-voltage
ATU Frequency range	3.5-30MHz
ATU Tuning range	16-500 Ohms
Tuner network type	6x5 L-match
RF-input connector type	BNC
RF-output connector type	BNC
Number of integrated L-pass band-filters	4
L-pass Band-Filter type	Chebyshev
Protective circuit	Temperature Input power Overcurrent
weight in kg/lbs	0.9 / 1.98
dimensions (HWD) in mm	30x207x90
Ambient operating temperature range	5°C - +40°C
max. device surface temperature	70°C

* SSB only, see 'operating modes and drive power'

** within the specified operating conditions, see 'operating mode and drive power'

*** 60W@16V operating voltage and peak drive power, this setting may violate other operating conditions

GENERAL TROUBLESHOOTING

fault description	Possible reasons	solution
Unable to turn on your PA500	power cord is not properly connected /or no power from the source	Connect power source correctly to the device
	power source is not capable to deliver the power	use proper power source
	internal fuse is open circuit	Device need to be repaired
Antenna tuning function does not work / tuner does not tune	No antenna connected	Connect a proper antenna usable for the operating frequencies of the PA500
	Antenna Tuner is configured into a manual-mode	Set it to auto-mode Or trigger a manual tuning event
	Antenna is already matched	-
No transmission / no amplification	Device in in BYPASS Mode	Set the device into TX Mode
	The Bandpass filter setting does not fit to the TX frequency	Set the correct filter for the TX frequency to be used
	No TX-Power from the Transceiver,	Check your Transceiver and connection
	Transceiver in SSB (no carrier)	Check your Transceiver and connection



When the PA500 current draw is too high (more than 15A), or a short circuit occurs, the internal fuse may blow. The unit will then no longer turn on. The device needs a service.



**Do not allow the maximum output power of the amplifier to exceed 40 W.
The PA switches to bypass mode when the maximum output power is exceeded by 1 dBm**



Using the PA500 at high power levels for extended periods can lead to overheating and potential damage to the PA stage.

AFTER-SALES SERVICE POLICY

If this kit is bought in the European union, this product has a limited one-year warranty effective from the date of purchase. This warranty covers only manufacturing and parts defects. It does not cover damage caused by lightning, excess voltage on the power supply, accidental damage or purposeful damage or misuse. If the product needs warranty repair within two weeks of receiving the product, DIY599 will pay for the shipping both ways. After two weeks DIY599 will pay only for return shipping. If the product is not covered under warranty, the customer pays for shipping both ways plus the cost of the repair.

Device LABEL and ID location

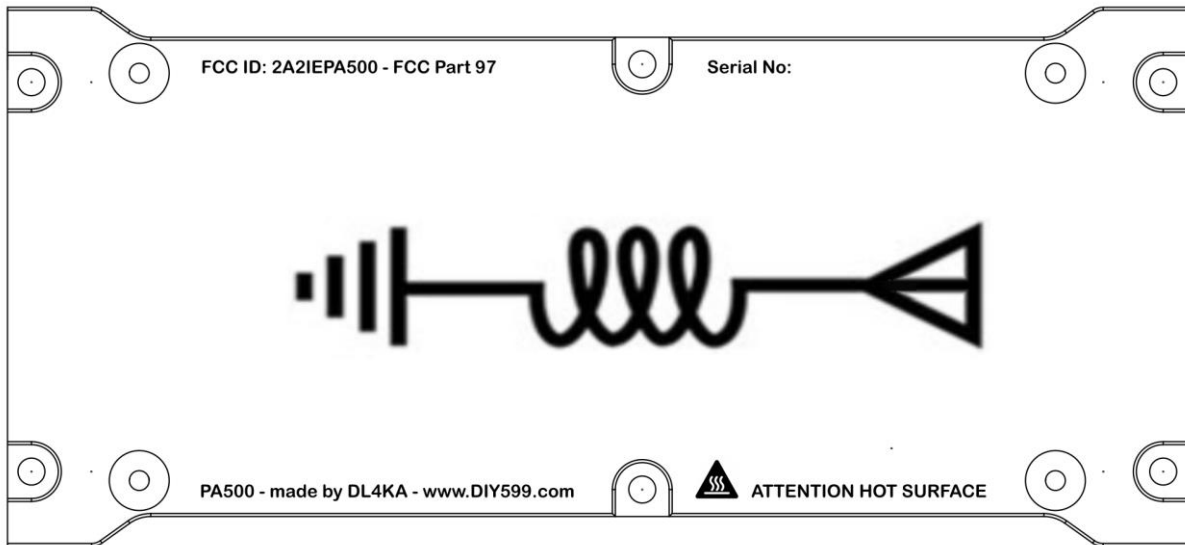

WARRANTY LIMITATIONS

Any of the following will void the warranty applicable to the product and its accessories:

- A. Modification-, removal-, or maintenance of the internal circuitry, without permission and authorization;
- B. Unauthorized change of product's embedded software;
- C. Immersion in liquid or signs of external damage;
- D. Warranty period expired;
- E. Product's serial number is missing, torn or blurred so we cannot determine if the radio is under warranty;
- F. Product was not bought from DIY599 or authorized distributor of DIY599.

None of the following conditions, are covered by the warranty:

- A. Damage caused by improper use by the user ;
- B. Damage caused by an accident ;
- C. Damage due to incorrect testing, maintenance, debugging, or other changes ;
- D. Damage is not caused by the material or the quality of production ;
- E. Damage to the shell or other external components due to improper use.

Contact us for service: service@DIY599.com

Note Amateur Radio Operation

DIY599.com is obligated as a manufacturer of amplifier devices to draw attention to the following legal provisions:

The following restrictive conditions apply:

This device is intended for use by radio amateurs within the meaning of the law on amateur radio in the valid amended. During operation of the device, the amateur radio law and supplementary laws and regulations must be observed.

WARRANTY TERMS

For amateur radio power amplifier PA500 legal guarantee determinations apply only if the device is operated in a manner corresponding to its intended use. This includes in particular the compliance with the operating limits mentioned in this manual.

DISCLAIMER of LIABILITY

All PA-500 specifications and descriptions are based on the latest information available at the time of this document's printing. As we are always striving to improve and update our products, ALL PRODUCT, PRODUCT SPECIFICATIONS AND DATA ARE SUBJECT TO CHANGE and DIY599 reserves the right to make changes and improvements at any time without further notice or obligation to notify any person or organization of such revisions or changes, made in order to improve the reliability, function, quality and design and/or performance of the PA500. Further, this Manual is provided "as is" and DIY599 shall not be liable for possible errors contained herein.

If there are any questions, please contact DIY599.com as follows:

by eMail: info@DIY599.com
by Phone: +49(0)33763-21484-0
by Mail: Oliver Harms
Gross Koeriser Str. 1b
15741 Bestensee